

APPLICATION NOTE

Visitor 3000 helps keep track of visitors to any organisation

Visitor can issue and print ID passes, make appointment bookings, and produce lists of people known to be on site. These lists may be viewed by security staff and department heads.

Extended features also allow Visitor to be tied into existing access equipment, such as magnetic swipe or proximity cards. Each pass or ID badge printed is completely personalised and carries your own firm's identity which can include your company logo.

Basic Configuration

Visitor can be used in a wide variety of situations either as a stand alone system or across a network. The diagram in fig. 1 shows what basic equipment is needed to run visitor on a single computer.

The picture in fig. 1 on the left shows what basic equipment is needed to run visitor on a single computer. Only three basic items are needed:

Computer System: Visitor is recommended to run on any computer that has either Windows XP / or Windows Vista/7 installed. If older operating systems are used then you should check that the system has at least 200MB of disk space available and at least 512Mb or RAM.

Camera: A USB connected webcam with at least five mega pixel resolution will be required if you are intending to include photos on passes. The camera should be compatible with WDM Capture and internal Visitor configuration settings will need to be set prior to use. A suitable camera mounting will also be needed.

Printer: A suitable label printer for issuing passes will be needed. A wide range of devices exist using different technologies e.g. thermal inkjet, laser, etc., both for monochrome or colour. The selection of printer will, in most cases, be influenced by the pass volume expected.

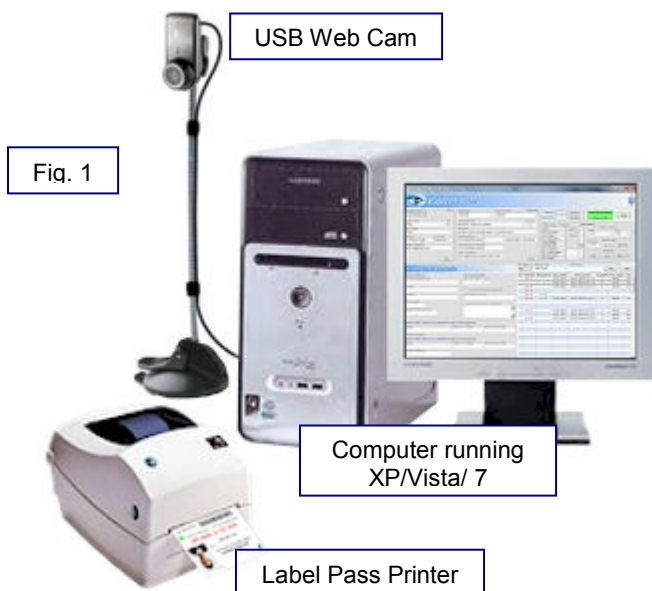

Network Configuration

On a Local Area Network (LAN) two modes of operation are possible 1. Client and, 2. Reception mode. This will allow department heads to view current lists of people who are on-site. See Fig 2.

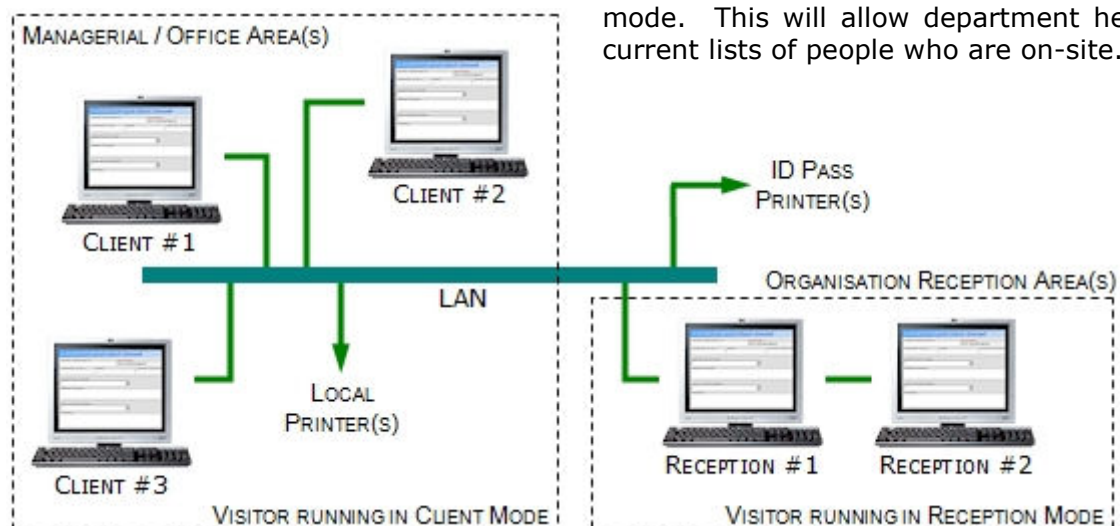

Fig. 2



Hardware Requirements

Computer:	
Processor	x86, > 1.3GHz (single core) for reasonable speed
Operating Systems	2008 Server, WinXP, Vista, Win7
Storage (Hard Disk) Installation	40MB absolute minimum
Storage (Hard Disk) Operation	200MB min. (20 visitors/day + pictures = 41MB/month)
Memory (RAM)	512MB minimum
CD ROM	Only required if installing from CD
Printer(s):	
ID Badges, Passes etc.	200-300dpi colour/mono (depends upon Pass/ID type)
Lists and General Print Output	Any inkjet/laser (not more than about 6 years old)
Camera(s):	
Passport (Head and Shoulders)	Webcam => 5MP Win XP and Win 7 compatible
Network:	Needed for client mode

Visitor 3000 Access Control

Visitor 3000 is modular in its architectural approach and this lends itself to a significant range of functionality beyond simply issuing ID passes. Typically, Visitor makes a natural front-end to any physical access control system providing a simple to use solution for both new and retrofit systems.

Nowadays ever more sophisticated security systems are on the increase and a very wide range of technologies exist. Chelsfield are able to supply custom modules that will talk to just about any type of system. We have significant experience in access control technologies, video pattern recognition, alarm verification, tracking systems and data encryption.

Whatever your needs, whether you are considering a small personnel access control system involving just a few nodes, or a site-wide structured control installation, Visitor 3000 eases integration and implementation. If you are at the planning stage it may well pay you to talk to your sales agent, just to see what may be possible, or you can contact us directly, particularly if you need to integrate seemingly incompatible systems or you discover you need something that can't be purchased off the shelf

Download Your Copy Today!

Visitor may be downloaded from the Chelsfield website: www.chelsfieldsolutions.co.uk. Just a single zip file is required which contains all the necessary installation and support files needed for a new installation.

Once installed, the software will have strictly limited functionality until you register with us. The registration process is very simple and only takes a couple of minutes via phone or e-mail. You will just need to provide your organisation name and address and registration number which can be found on the registration screen.

Download YOUR COPY today and contact us to find out how Visitor can benefit your organisation. It's inexpensive and payment options, including a LOW COST RENTAL PLAN, are available.

Chelsfield Solutions

Unit 3 Station Approach March Cambridgeshire PE15 8SJ
Tel: +44 (0)1354 600488 Email: sales@chelsfieldsolutions.co.uk www.chelsfieldsolutions.co.uk